

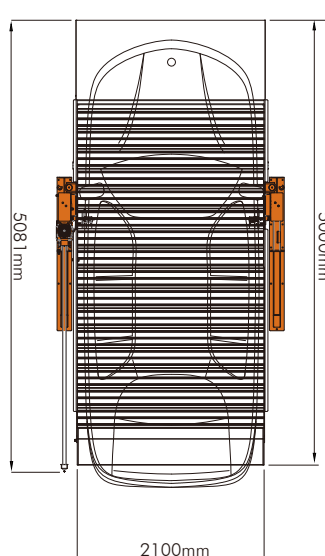

Hydro-Park 1132 is the strongest two post simple parking lift, offering 3200kg capacity to stack SUV, van, MPV, pickup, etc. 2 parking spaces are offered on one existing space, suitable for permanent parking, valet parking, car storage, or other places with attendant. Operation can be easily made by a key switch panel on control arm. The feature of post sharing allows more installations in limited space.

*Lifting capacity 3200kg
Car height on ground up to 2050mm.
Platform width up to 2500mm.
Directly driven by dual hydraulic cylinders
Synchronization chain keeps platform level under all conditions
Mechanical anti-falling locks enable multiple stopping heights.
Electric lock release provides easier operation.
24v control voltage avoids electric shock
Galvanized platform, high-heel friendly
Bolts & nuts passing 48hrs Salt Spray Test.
Akzo Nobel powder coating provides long lasting surficial protection*

Dimensions & Specifications

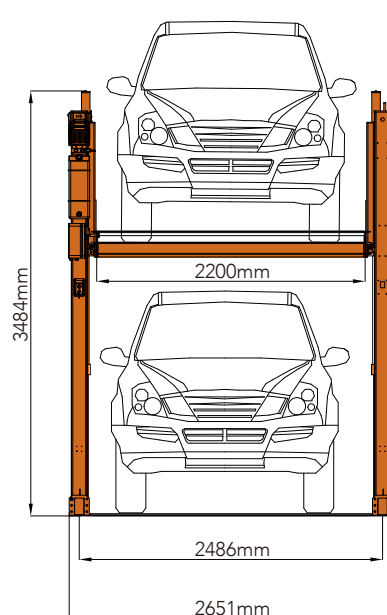
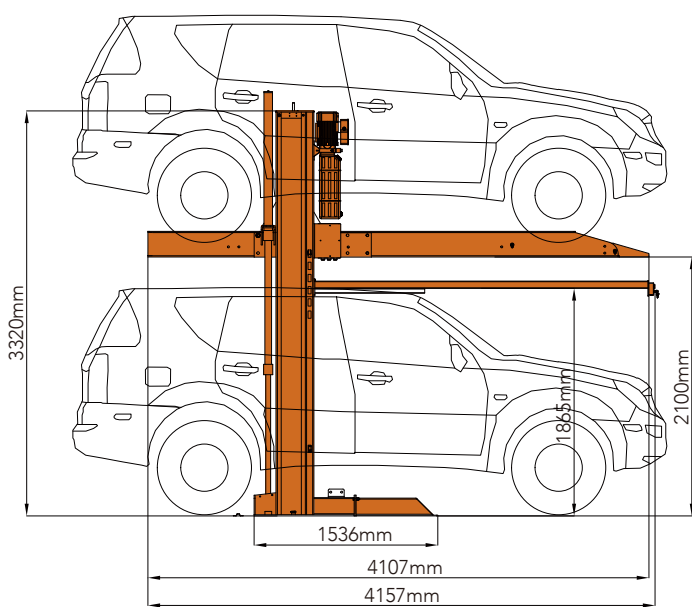

Lifting capacity	3200kg
Lifting height	2100mm
Usable platform width	2200mm
Power unit	3Kw hydraulic pump
Available voltage of power supply	100V-480V, 1 or 3 Phase, 50/60Hz
Operation mode	Key switch
Operation voltage	24V
Safety lock	Dynamic anti-falling lock
Lock release	Electric auto release
Rising / descending speed	<40s
Finishing	Powder coating